

example-mapping...

Quality Without A Name

Rob Westgeest & Marc Evers

www.qwan.eu

IN

Before we start

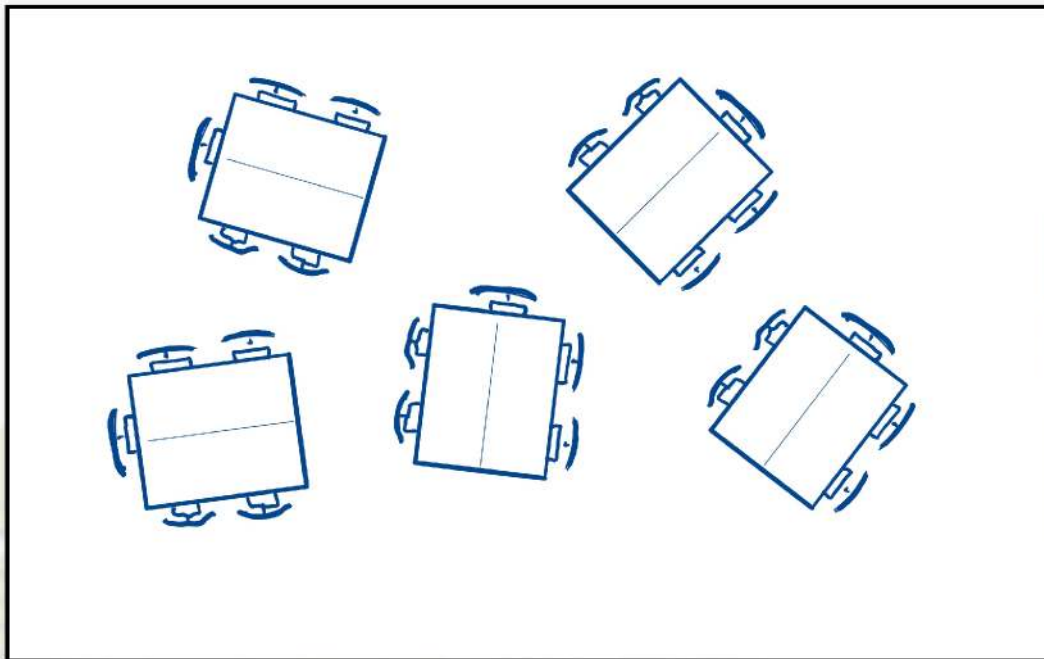



Cabaret

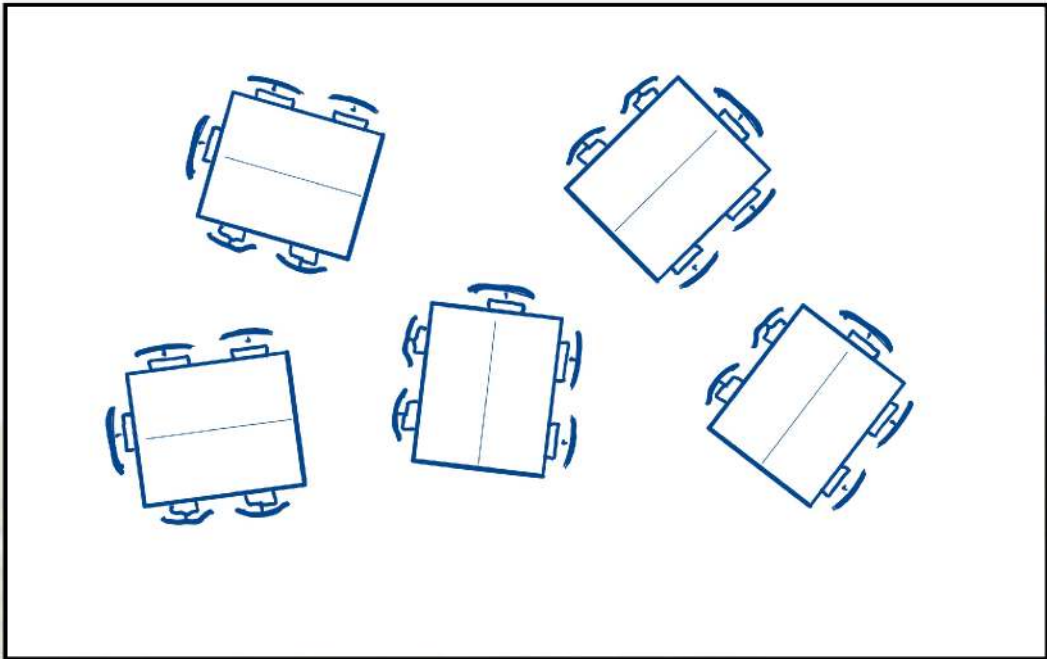



example-mapping...

Quality Without A Name

Rob Westgeest & Marc Evers

www.qwan.eu



Quality Without A Name



marc@qwan.eu | willem@qwan.eu | rob@qwan.eu

We take a systemic approach to help software development organizations become better and more fun to work.

QWAN is a partnership of independent consultants-developers.



What we do

increase business value from software development

- Consultancy en Mentoring
- Training
- Development
- Organizing conferences



Our learning vision

Learning by doing



Goal

More effective and efficient refinements

Goal

*More effective and efficient refinements
and more fun*





Developer

- Spend lot of time in endless refinement sessions?
- Vague or incomplete requirements?
- Stories too big?



Product Owner

- Find that your developers misunderstand you?
- Spend lot of time in endless refinement sessions?



Testers

- Find lots of bugs?
- Long detailed tests, full of technical details?
- Given up on getting the business on board?

Benefits

- Discover what you don't know
- Discover acceptance tests
- Discover new business rules
- Discover story splits

Preparations

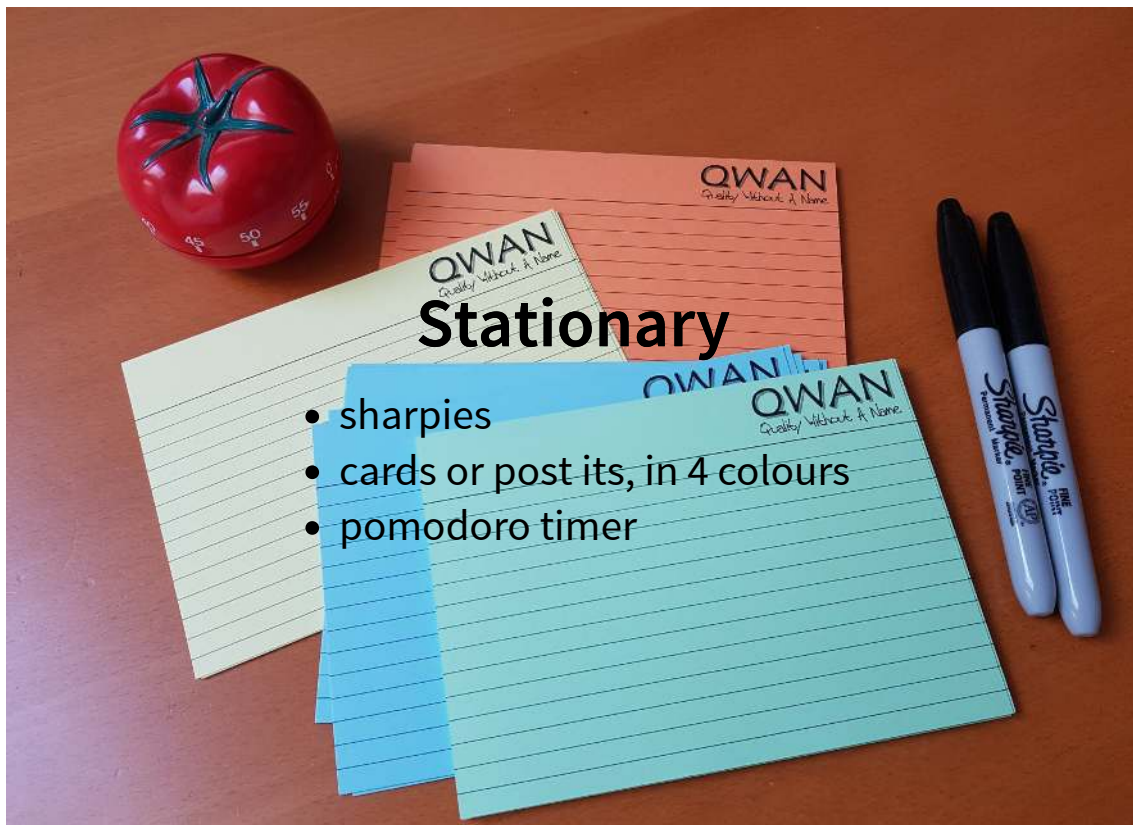

- sharpies
- cards or post its, in 4 colours
- pomodoro timer

Who's present

product owner, developer, tester



Who's present

product owner, developer, tester

customer, support staff, installer, manager etc. whoever is relevant



Case:



Order management

The story

Confirm Order 

As a Thirsty Client
I want to confirm my order
So that I can enjoy my drinks

On the flipside

Acceptance Criteria:

- order contains alcoholic beverages, then client must be >18
- Invoice based payments only when client is credible
- Direct delivery on mobile based payments
- ideal or bank transfer, then deliver after pay
- Deliver order when all in stock
- Client is updated by email.

Steps

- Layout story
- Layout rules
- Layout examples
- Add questions along the way

QWAN
Quality Without A Name

Layout Story

QWAN
Quality Without A Name

Layout Rules

"18+ for alcoholic beverages"

QWAN
Quality Without A Name

Add questions along the way

Reds (orange is the new red)

QWAN
Quality Without A Name

Layout Examples

Be specific & concrete on the examples

Example

QWAN
Quality Without A Name

"order with a coke and a beer
confirmed by 17 year old
confirmation rejected"

Notes on Examples

QWAN
Quality Without A Name

- Sad paths and happy paths
- Sad paths expose ambiguities
- Concrete examples help find questions



Thumb vote

- Too many unknowns
- Too much blue or green
- Sometimes more example mapping sessions

Take picture

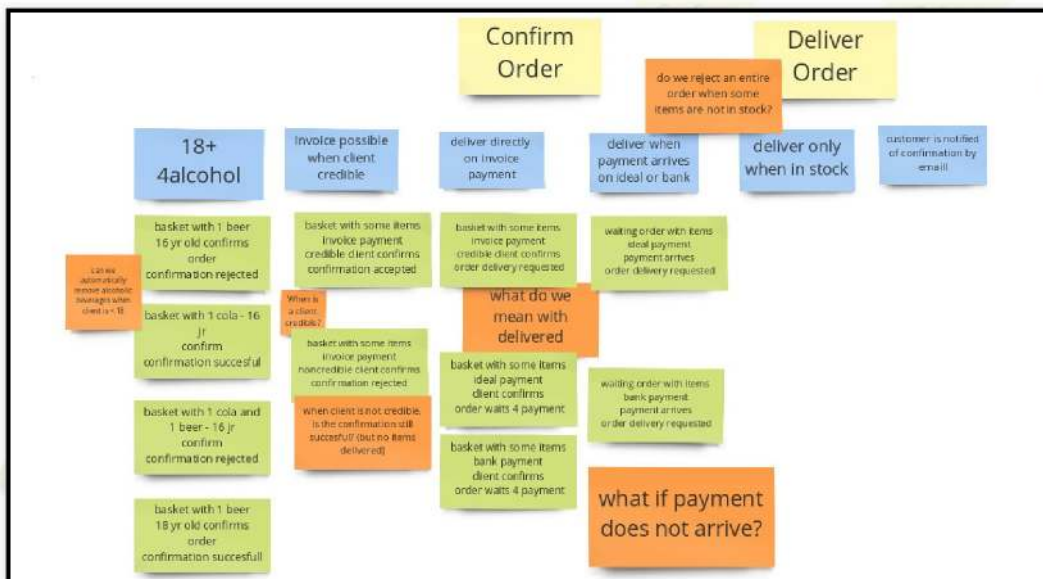

Recommendations

- Goal is not to answer all questions, but to find out what we still don't know.
- Imagine it is 1920
- Do it at last responsible moment
- One pomodoro - one story
- Translate to Gherkin or whatever you use later

Example to Gherkin

```
Scenario:  
Given An Order with "beer" and "cola"  
And My age is "17"  
When I confirm the order  
Then the order is rejected with message "you cannot order alcoholic b
```

References

- Matt Wynne, [Introducing Example Mapping](#) (Dec 2015)
- Aslak Hellesoy, [Example Mapping Webinar](#) (Feb 2018)
- George Dinwiddie, [The Three Amigos: All for One and One for All](#) (Nov 2011)
- Mike Cohn, [The Forgotten Layer of the Test Automation Pyramid](#) (Dec 2009)
- Lisa Crispin & Janet Gregory, [Using the Agile Testing Quadrants](#) (Nov 2011)
- Alistair Cockburn, [Hexagonal Architecture](#) (2006)
- Gáspár Nagy, [Balancing Scenarios and Unit tests](#) (2017)